

TORNADO 2

- FDA & ATEX possible at the same time
- low maintenance
- extreme spraying widths
- continuous spray strength



- Validatable cleaning process
- Cleaning diameter up to 27 m
- flow rate between 243 – 378 lpm
- energy-saving motor technology
- installation aperture only 100/220 mm
- no ball bearings, self-cleaning
- function monitoring with SMW 100, Vericlean



The Tornado 2 is a powerful target jet cleaner with orbital 360° spray pattern. The Tornado 2 is driven by the cleaning medium at a pressure of 4 to 10 bar. Turbine-driven, a radial and axial rotation of the nozzle head is generated. This creates aligned jets of liquid through two long nozzles with a strong impact effect up to a diameter of 27 metres. By circulating jets of liquid, a completing spray pattern with high coverage and full coverage is thus produced within 5.5 to 12 minutes.

Thanks to optimum flow control, smooth-running mechanics without ball bearings and a hygienic sealing concept, the energy used on the unit unfolds in a very short time. The energy used on the unit into a powerful cleaning effect. The orbital cleaning behaviour enables the best possible use of the cleaning liquid or chemical additives. For use in hygiene-sensitive areas, the unit keeps itself permanently clean with a self-cleaning nozzle and empties itself automatically after use in vertical operation. The use of the unit always conserves resources and requires minimal wear and maintenance.

The Tornado meets the highest hygiene and safety standards and can be used in EX zones and FDA applications at the same time. During a long service life, this unit will always prove to be a reliable partner for your cleaning tasks. Tornado orbital cleaners are available in many connection variants. Optionally, the cleaning process of a Tornado can be permanently and non-invasively monitored by SMW 100 or Vericlean. The Tornado is one of the latest and most effective developments on the market for cleaning technology.

Tanks and containers in the brewing, beverage, dairy processing, food, pharmaceutical, chemical and transport industries and on ships are frequent areas of application for this product.

Technical data:

Max. cleaning diameter:	27 meter (88.6 ft)
Spray pattern:	360° orbital
Pressure range:	4 – 10 bar (58 – 145 psi)
Flow rate:	243 – 378 LPM (14.6 – 22.7 m ³ /h) (64.2 – 99.9 US gpm)
Insertion opening:	min. Ø 100/220 mm (3.94/8.66 Inch)
Preferred mounting position:	any angle
Weight:	approx. 3.1 KG (6.8 lbs)
Materials:	Stainless Steel 316L (1.4404), C.PTFE, PTFE
Pipe connection:	1.5" BSP (NPT) female
Optional Pipe Connections:	1.5" OD Splint (38.1x1.6mm), DN40 Splint (41.15x1.5mm), DN50 Splint (53.25x1.5mm), 1.5" Clamp
Nozzle characteristics:	2 x 11 mm Nozzles
Certifications:	3.1, 2.2, ATEX, FDA, Regulation (EC) No 1935/2004
Max. operating temperature:	95°C (203°F)
Max. ambient temperature:	140°C (284°F), 30Min.

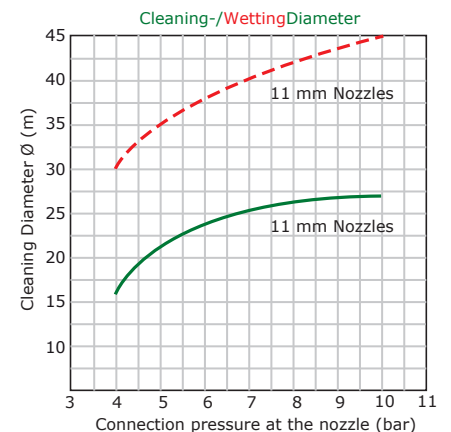
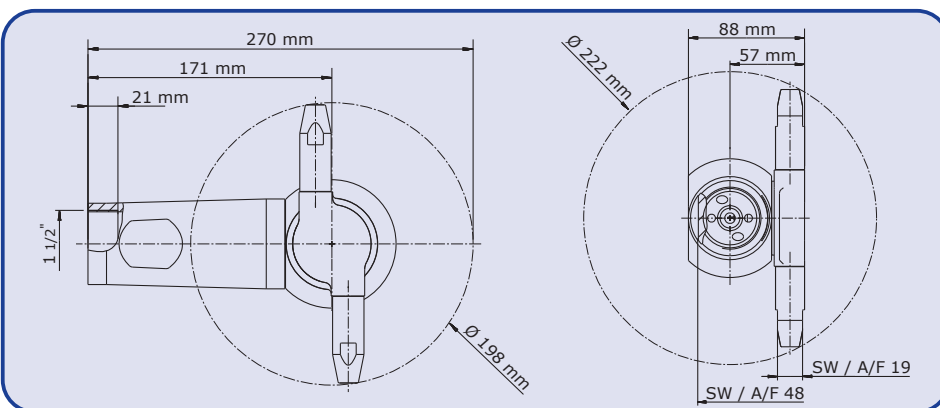
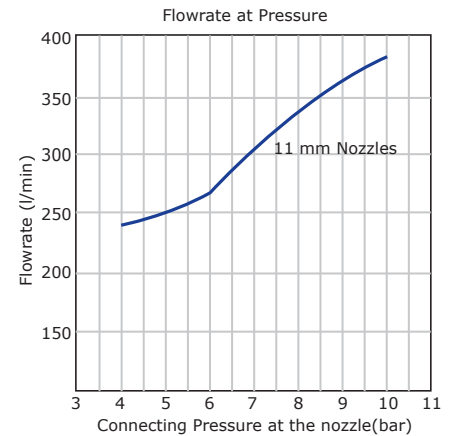

The data, technical data and information presented do not release the user from the obligation to check the suitability of the products supplied for the intended application. All information is without guarantee. (Status: 28.02.2022-71427321893-1888948-71042)